

DIAPHRAGM CHUCK

# GC Cage type Gear Chuck

"High Precision" "Corresponding to many kinds of work-pieces by one chuck" "Designed Specification"

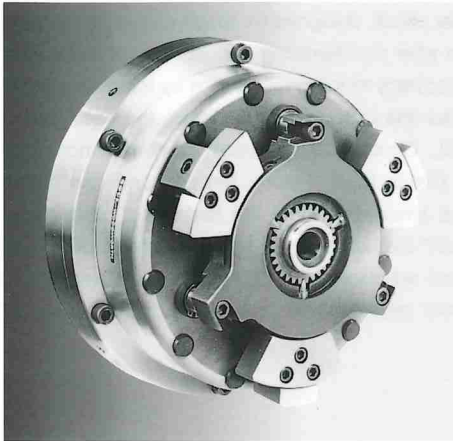

The GC [Cage type Gear Chuck] is dust-proof and water proof type of chuck and features interchangeable cage which is designed according to the gears to be machined. The GC [Gear Chuck] is based on high precision diaphragm chuck. A stopper is built in the cage. Three gear pins clamping tooth surface are made in compliance with the quantity of gears, module, pitch dia, and angle of torsion. When changing cages, loosen slightly 3 parcel of setting bolts, and unfasten the cages by turning anti-clock wisely and then set the cage for next operation in the opposite way. In this case, adjustment of concentricity is not necessary. There are 4 kinds of Diaphragm Chucks being used under this way which general numbers are #8, #10, #13, and #17 and for each of types, Draw Bar type / Built in Air Cylinder type / Push Pull type / Built in Finger mechanism type are available according to the way of use.

### Gear pin (sintered carbide tool)

For cages, use gear pin of either wedge type or conical type. The gear pins are hold inside cages by spring clips. And appropriate space at pin setting hole for moving adjustment.

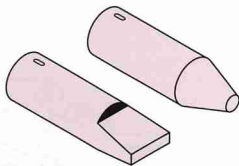

### Interchangeable cages

In case of medium scale production to be repeatedly done every month, it is not so rare to use 20-25 kinds of cages only by one set of chuck. The standardization of designs for both chucks and cages enables to reduce cost of exchanging time and production. Economical work-holders with ensuring quality have been developed.



### Dimension diagram

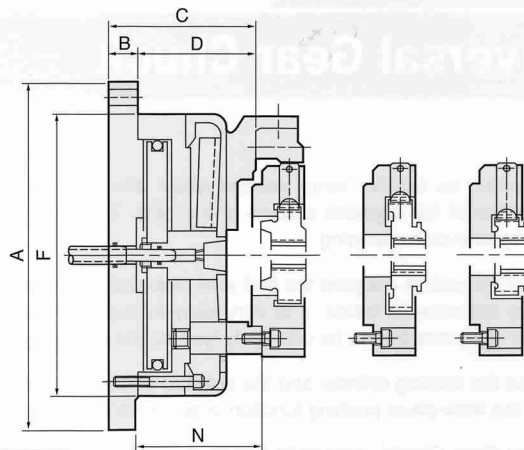

### Standard dimensions

Model No.	A	B	C	D	F	N
GC-8012	246	19.1	96.8	77.7	212.9	70
GC-10012	284	19.1	96.8	77.7	251.0	85
GC-13012	360	19.1	108.0	88.9	327.2	85
GC-17012	476	19.1	109.5	90.4	428.9	85

### Standard specifications

Model No.	Max. Clamping force kN (kgf)		Jaw Q'ty	Jaw stroke mm	Clamping range (Pitch round)mm	Pneumatic pressure MPa (kgf/cm <sup>2</sup> )	Weight kg
	Single	Double					
GC-8012	7.1 (720)	14.1 (1,440)	3	0.25	40~70	0.45 (4.59)	20.2
GC-10012	11.2 (1,140)	22.3 (2,280)	3	0.25	70~100		26.5
GC-13012	20.0 (2,040)	40.0 (4,080)	3	0.35	100~160		43.2
GC-17012	35.3 (3,600)	70.6 (7,200)	3	0.40	160~250		89.1

### Practical examples

#### Push-pull type (By draw bar)

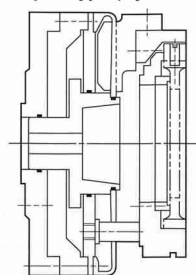

For : Gear differential ring  
Clamping dia. :  $\phi$ 60

#### Fixation type

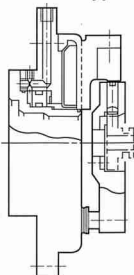

For : Gear reverse idler  
Clamping dia. :  $\phi$ 80

#### Finger clamp combination type

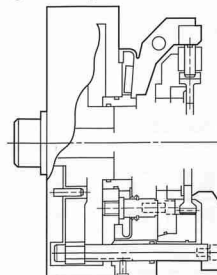

For : Ring gear  
Clamping dia. :  $\phi$ 180

#### Built in cylinder type

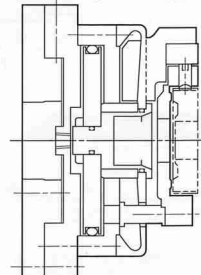

For : Gear  
Clamping dia. :  $\phi$ 80