

Collet Chuck

AC Hand-Lok Collet & Arbors models type

Best choice for small-lot I.D. clamping !

The Hand-Lok Collet Arbor series is one of the AC Collet Arbor series for easy use of AC Arbor type chuck which has great performance in I.D. clamping, by applying the manual type collet installation device with CAM mechanism. The centering location is designed to be $\phi 80$ for all sizes [from December 1994 on] and also the outer diameter "A" is set only in 2 sizes then you just need to prepare 1 piece of adapter plate to use AC Arbor. Especially for NC lathe, this Hand-Lok Arbor is designed to have small over hang length and done heat-treated in order to make it scratch proof, then soft jaws formed into "A" diameter can clamp without removing the wedge type power chuck. Another advantage is highly accurate concentricity, 4 portions of adjusting screws on Hand-Lok allows to obtain great concentricity approximately 10μ .



Dimension diagram

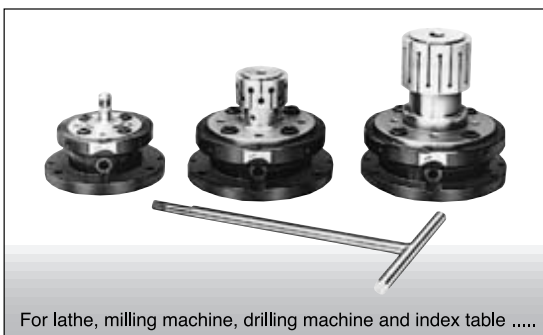
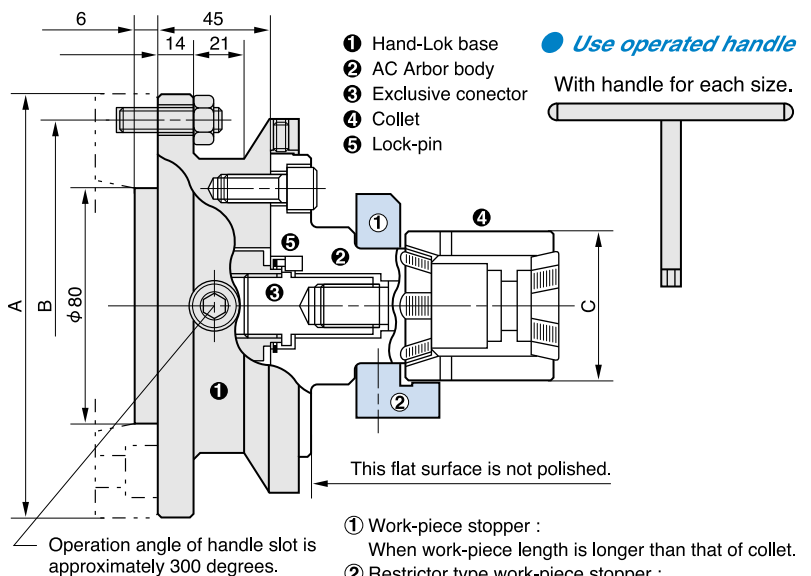

For lathe, milling machine, drilling machine and index table

● Standard Dimensions

Model No.	Hand-Lok base	AC Collet Arbor	Exclusive connector	A	B	C Clamping range for work-piece
AC-21HL	1 type	AC-2110	AC21C	138	118 P.C.D M-10	12.70 ~ 16.64
AC-22HL		AC-2210	AC22C			15.06 ~ 19.21
AC-23HL		AC-2310	* AC23C			18.24 ~ 25.37
AC-24HL	2 type	AC-2410	* AC24C			22.23 ~ 31.72
AC-25HL		AC-2510	* AC25C			28.58 ~ 41.25
AC-26HL	3 type	AC-2610	* AC26C			170
AC-27HL		AC-2710	* AC27C	49.20 ~ 72.21		
AC-28HL	4 type	AC-2810	—	65.07 ~ 91.26		
AC-29HL		AC-2910	—	84.12 ~ 113.46		

* For the 23C to 27C, the exclusive lock-pin (stopper) is used. ● Please choose a standard collet from the selection table on page 15

● Short Dimensions

Model No.	Hand-Lok base	AC Collet Arbor	Exclusive connector	A	B	C Clamping range for work-piece
AC-81HL	1 type	AC-8100	AC81C	138	118 P.C.D M-10	12.70 ~ 16.64
AC-82HL		AC-8200	AC82C			15.06 ~ 20.24
AC-83HL		AC-8300	* AC83C			18.24 ~ 25.40
AC-84HL	2 type	AC-8400	* AC84C			22.23 ~ 33.00
AC-85HL		AC-8500	* AC85C			28.58 ~ 41.70
AC-86HL	3 type	AC-8600	* AC86C			170
AC-87HL		AC-8700	* AC87C	49.20 ~ 71.65		

* For the 83C to 87C, the exclusive lock-pin (stopper) is used. ● Please choose a short collet from the selection table on page 17

The marked is parts are light cutting only. Please do not tightening up strongly. (Handle torque within 980N.cm)

CAUTION

- colored models are for light duty cutting operation only. Do not tight handle strongly since it might break the expander.
- Clamping Hand-Lok by power chuck are slightly inferior compared with bolt-on types.
- When power chuck clamps the Hand-Lok Arbor, please make sure that ① the clamping force is maximum, ② Clamping jaw depth is 14mm or more, ③ Run-out of the end surface of chucks. Cutting condition has to be reduced when using scroll chucks, since they have weaker clamping force than power chucks.